

## Potential Antisecretory Antidiarrheals. 1. $\alpha_2$ -Adrenergic Aromatic Aminoguanidine Hydrazones<sup>†</sup>

Barnett S. Pitzele,\* Alan E. Moormann, Gary W. Gullikson, David Albin,<sup>†</sup> Robert G. Bianchi, Prima Palicharla, Elizabeth L. Sanguinetti, and D. Eric Walters

Preclinical Research, G.D. Searle & Co., Skokie, Illinois 60077. Received July 31, 1987

Guanabenz, a centrally acting antihypertensive agent, has been shown to have intestinal antisecretory properties. A series of aromatic aminoguanidine hydrazones was made in an effort to separate the antisecretory and cardiovascular activities. Benzaldehyde, naphthaldehyde, and tetralone derivatives were synthesized. The compounds were evaluated in the cholera toxin treated ligated jejunum of the rat and in the Ussing chamber using a rabbit ileum preparation. A number of compounds, including members of each structural class, were active upon subcutaneous administration in the rat. Active compounds were determined to be  $\alpha_2$ -adrenergic agonists by yohimbine reversals of their Ussing chamber activities. The compound displaying the best separation of activities was the aminoguanidine hydrazone of 2,6-dimethyl-4-hydroxybenzaldehyde (20).

The traditional symptomatic therapy for diarrhea has largely been through control of the transit time of intestinal contents. These therapeutic agents, natural and synthetic opiate agonists,<sup>1</sup> act primarily by inhibiting propulsive activity of the gut.<sup>1</sup> Thus the contact time between the intestinal contents and the absorptive intestinal surface is increased, thereby increasing fluid absorption. New antimotility antidiarrheals with greater specificity of action are continuously being developed.<sup>2,3</sup>

Although most antidiarrheal research has focused on antimotility compounds, a large fraction of the diarrhea cases that develop do so because of physiological hypersecretory states in the intestine, rather than hypermotility states.<sup>4</sup> Thus a more direct therapy would be one that addressed this hypersecretory state, rather than circuitously approaching the issue via suppression of peristalsis. Two new antidiarrheal agents, lidamidine and rolgamidine, exert their antidiarrheal action by a varying combination of both secretion and propulsion inhibition.<sup>5</sup> We felt that a drug that specifically blocks the hypersecretion found in diarrhea would be a clinically useful therapeutic regimen.

It has recently been shown that certain drugs with  $\alpha_2$  adrenoceptor agonist action, clonidine (1) and lofexidine (2), are potent antidiarrheals<sup>6,7</sup> (Chart I). That clonidine's antidiarrheal action is mediated by an  $\alpha_2$ -agonist mechanism has been demonstrated by yohimbine reversal<sup>8</sup> of the clonidine-induced blockade of castor oil induced diarrhea.<sup>8b</sup> Lidamidine also acts by an  $\alpha_2$  mechanism in vivo, but must be metabolized to exert in vitro activity. Lidamidine (3) can be metabolized in vitro by rat liver microsomes to an  $\alpha_2$ -adrenergic agonist (apparently the *N*-desmethyl metabolite) which reverses the aminophylline-augmented potential difference (PD) across rabbit ileum in an Ussing chamber.<sup>9</sup> Indeed, a number of  $\alpha_2$  agonists have been shown to inhibit intestinal secretion, both in vitro<sup>10</sup> and in vivo.<sup>11</sup>

Thus, these  $\alpha_2$  agonists exert at least part of their action by an antisecretory, in addition to an antimotility, mechanism.<sup>8a,9,10</sup> A peripherally acting  $\alpha_2$  antisecretory antidiarrheal agent that could not penetrate the blood-brain barrier would be expected to be devoid of the hypotensive action of such centrally acting  $\alpha_2$  agonists as clonidine, lofexidine, or guanabenz (4). We started a program of

Chart I

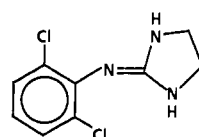

CLONIDINE (1)

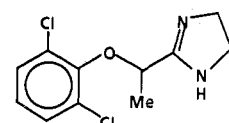

LOFEXIDINE (2)

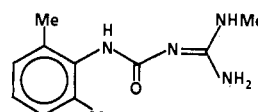

LIDAMIDINE (3)

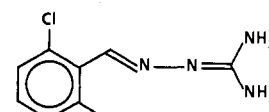

GUANABENZ (4)

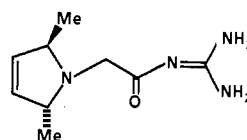

ROLGAMIDINE (4a)

synthesis of some aminoguanidine hydrazones of aromatic aldehydes and ketones, to make intestinal antisecretory

- (1) Awouters, F.; Niemegeers, C. J. E.; Janssen, P. A. *Annu. Rev. Pharmacol. Toxicol.* 1983, 23, 279.
- (2) Adelstein, G. W.; Yen, C. H.; Dajani, E. Z.; Bianchi, R. G. *J. Med. Chem.* 1976, 19, 1221.
- (3) Dajani, E. Z.; Bianchi, R. G.; East, P. F.; Bloss, J. L.; Adelstein, G. W.; Yen, C. H. *J. Pharmacol. Exp. Ther.* 1977, 203, 512.
- (4) (a) Pietrusko, R. G. *Am. J. Hosp. Pharm.* 1979, 36, 757. (b) Powell, D. W.; Field, M. In *Secretory Diarrhea*; Field, M., Fordtran, J. S., Schultz, S. G., Eds.; American Physiological Society: Bethesda, MD, 1980.
- (5) (a) Mir, G. N.; Alisto, R. L.; Sperow, J. W.; Eash, J. R.; Krebs, J. B.; Yelnosky, J. *Arzneim.-Forsch. (Drug Res.)* 1978, 28II, 1448. (b) Beattie, D. E.; Dover, G. M.; Ward, T. J. *J. Med. Chem.* 1985, 28, 1617.
- (6) Lal, H.; Shearman, G. T.; Ursillo, R. C. *J. Clin. Pharmacol.* 1981, 21, 16.
- (7) Lal, H.; Shearman, G. T. *Drug Dev. Res.* 1981, 1, 37.
- (8) (a) Nakaki, T.; Nakadate, T.; Yamamoto, S.; Kato, R. *Nahrung-Schmiedeberg's Arch. Pharmacol.* 1982, 318, 181. (b) Spraggs, C. F.; Bunce, K. T. *J. Pharm. Pharmacol.* 1983, 35, 321.
- (9) Albin, D.; Burton, E.; Gullikson, G.; Yang, P. C.; Bauer, R. 67th Annual Meeting of the Federation of American Societies for Experimental Biology, Abstracts, No. 6302, Chicago, IL, April 1983.
- (10) Gullikson, G. W.; Albin, D.; Yang, P. C.; Bauer, R. 67th Annual Meeting of the Federation of American Societies for Experimental Biology, Abstracts, No. 6300, Chicago, IL, April 1983.

<sup>†</sup> This paper has been presented in part; see: Moormann, A. E.; Pitzele, B. S.; Gullikson, G. W.; Bianchi, R. G.; Monroy, M.; Rubin, B.; Casler, J.; Grebner, M. *Programs and Abstracts*, Joint Great Lakes and Central Regional Meeting, Kalamazoo, MI; American Chemical Society: Washington, DC, 1984; Abstract 237.

<sup>†</sup> Present address: Agis Industries, Yeruham, Israel.

Table I. Aminoguanidine Hydrazones of Some Substituted Benzaldehydes

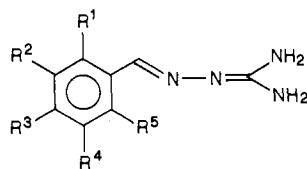

no.	R <sup>1</sup>	R <sup>2</sup>	R <sup>3</sup>	R <sup>4</sup>	R <sup>5</sup>	rat cholera toxin: ID <sub>50</sub> <sup>a,b</sup> mg/kg	Ussing chamber <sup>c</sup>
4 <sup>d</sup>	Cl	H	H	H	Cl	1.3 (0.7-2.0)	+
13	H	H	H	NH <sub>2</sub>	Me	I	-
14	H	NH <sub>2</sub>	H	H	Me	I	NT
16	Me	NH <sub>2</sub>	H	NH <sub>2</sub>	Me	I	NT
17	Me	H	H	H	Me	1.6 (0.9-2.4)	+
18	Me	H	H	H	H	I	-
19	Me	H	Me	H	Me	16.6 (9.4-30.5)	-
20	Me	H	OH	H	Me	3.4 (2.0-5.1)	-
21	H	Me	OH	Me	H	I	-
22	Me	H	OMe	H	Me	27.0 <sup>e</sup>	-

<sup>a</sup> Subcutaneous administration of drug. I = inactive. Highest dose tested is 20 mg/kg. <sup>b</sup> Parentheses contain 95% confidence limits. <sup>c</sup> + = active at  $1.0 \times 10^{-6}$  M;  $\pm$  = active at  $1.1 \times 10^{-5}$  M; - = inactive; NT = not tested. Reversal of aminophylline-induced PD increase. <sup>d</sup> Guanabenz. <sup>e</sup> Limits not calculable.

Table II. Aminoguanidine Hydrazones of Some Derivatives of 17

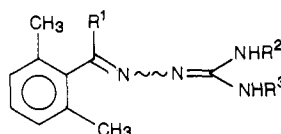

no.	R <sup>1</sup>	R <sup>2</sup>	R <sup>3</sup>	syn/anti	rat cholera toxin: ID <sub>50</sub> <sup>a,b</sup> mg/kg	Ussing chamber <sup>c</sup>
7	Me	H	H	syn	13.3 (6.7-26.2)	$\pm$
8	Me	H	H	anti	I	-
32	H	-CH <sub>2</sub> CH <sub>2</sub> -	H	anti	7.9 (4.5-12.7)	NT

<sup>a</sup> Subcutaneous administration of drug. I = inactive. Highest dose tested is 20 mg/kg. <sup>b</sup> Parentheses contain 95% confidence limits. <sup>c</sup> + = active at  $1.0 \times 10^{-6}$  M;  $\pm$  = active at  $1.1 \times 10^{-5}$  M; - = inactive; NT = not tested. Reversal of aminophylline-induced PD increase.

$\alpha_2$ -agonistic guanabenz analogues that could not reach the central compartment.

Replacement of the chloride residues of guanabenz with groups possessing electron-donating inductive effects might increase the basicity of the aminoguanidine group enough to increase the protonation of the molecule to the point that very little if any would penetrate the blood-brain barrier. A similar approach lead to the synthesis of rolgamidine (4a) as a peripherally acting analogue of guanfacine.<sup>5b</sup>

**Synthetic Chemistry.** In most cases, the commercially available appropriate aldehyde or ketone was condensed with aminoguanidine nitrate or sulfate in methanol in the presence of sulfuric acid, giving the desired product.

The aromatic amino-substituted hydrazones (13, 14, 16) were synthesized as shown in Scheme I. The appropriate methylbenzaldehyde was nitrated in sulfuric acid. In the case of 2-methylbenzaldehyde, the resulting inseparable mixture was converted to a mixture of the corresponding Schiff bases (9, 10) by using cyclohexylamine. This mixture was separated on a silica gel column, and the individual isomers were (separately) treated sequentially with acid to release the aldehyde (11, 12), aminoguanidine to form the hydrazone, and then hydrogen in the presence of palladium to give the desired products 13 and 14.

The issue of syn and anti isomerism also arose in the cases of the tetralone and indanone derivatives 27-31

Table III. Aminoguanidine Hydrazones of Some Fused Aromatic Compounds

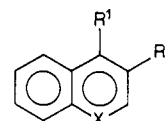

no.	R <sup>1</sup>	R <sup>2</sup>	X	rat cholera toxin: ID <sub>50</sub> <sup>a,b</sup> mg/kg	Ussing chamber <sup>c</sup>
23	CH=NN=C(NH <sub>2</sub> ) <sub>2</sub>	H	CH	34.6 <sup>d</sup>	-
24	H	CH=NN=C(NH <sub>2</sub> ) <sub>2</sub>	CH	I	-
25	CH=NN=C(NH <sub>2</sub> ) <sub>2</sub>	H	N	I	-

<sup>a</sup> Subcutaneous administration of drug. I = inactive. Highest dose tested is 20 mg/kg. <sup>b</sup> Parentheses contain 95% confidence limits. <sup>c</sup> + = active at  $1.0 \times 10^{-6}$  M;  $\pm$  = active at  $1.1 \times 10^{-5}$  M; - = inactive; NT = not tested. Reversal of aminophylline-induced PD increase. <sup>d</sup> Limits not calculable.

(Table IV). Proton NMR spectra indicated that only one isomer was present in each case. The spectra resembled each other, with one aromatic proton (the C-8 proton in tetralone hydrazones or C-7 in indanone hydrazones) at distinctively lower field in each case. Examination of Dreiding models showed the isomer with the guanidine function anti to the aromatic ring to be less crowded, as expected. In order to unequivocally confirm this configuration, one compound, the 6-methoxytetralone derivative 29, was subjected to single-crystal X-ray diffraction. The

(11) Doherty, N. S.; Hancock, A. A. *J. Pharmacol. Exp. Ther.* 1983, 225, 269.

Table IV. Aminoguanidine Hydrazones of 1-Tetralones and Indanone

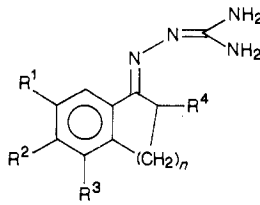

no.	R <sup>1</sup>	R <sup>2</sup>	R <sup>3</sup>	R <sup>4</sup>	n	rat cholera toxin: ID <sub>50</sub> <sup>a,b</sup> mg/kg	Ussing chamber <sup>c</sup>
26	H	H	H	H	2	30.6 <sup>d</sup>	-
27	H	H	H	H	1	I	NT
28	MeO	H	H	H	2	I	NT
29	H	MeO	H	H	2	20.5 (9.4-56.9)	NT
30	H	H	MeO	H	2	I	NT
31	H	H	H	Me	2	I	NT

<sup>a</sup>Subcutaneous administration of drug. I = inactive. Highest dose tested is 20 mg/kg. <sup>b</sup>Parentheses contain 95% confidence limits. <sup>c</sup>+ = active at  $1.0 \times 10^{-6}$  M;  $\pm$  = active at  $1.1 \times 10^{-6}$  M; - = inactive; NT = not tested. Reversal of aminophylline-induced PD increase. <sup>d</sup>Limits not calculable.

## Scheme I

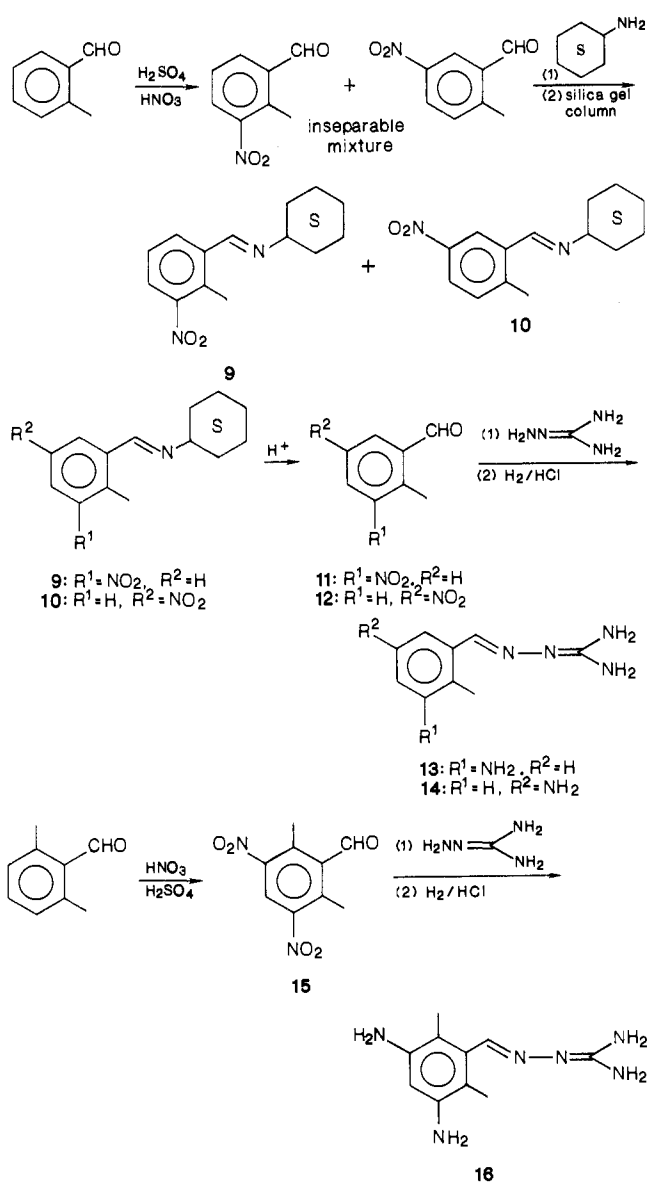

anti structure was indeed confirmed.

**Computational Chemistry.** Molecular modeling studies employed Chemlab II, which includes a modified version of Allinger's MM2 program<sup>12</sup> and additional pa-

rameters generated by the method of Hopfinger and Pearlstein.<sup>13</sup> The X-ray crystallographic data were used as starting geometries, and conformational energies were calculated by using the approximate ab initio method PRDDO.<sup>14</sup>

**Pharmacology.** In order to determine the effect of the test compounds on intestinal fluid movements in an intact animal, we used the rat cholera secretion model.<sup>15</sup> A ligated jejunal loop was injected with cholera toxin following subcutaneous administration of drug to the rat. After 4 h, the rat was sacrificed and the length and fluid content of the loop were measured. The ID<sub>50</sub> of the compound was calculated from data on at least two doses and from at least two different experiments, by the method of maximum likelihood.<sup>16</sup>

Intestinal antisecretory drugs that act by an  $\alpha_2$ -adrenergic mechanism have been demonstrated to inhibit the in vitro increases in intestinal potential difference caused by diarrhea-inducing secretagogues.<sup>10</sup> Experiments to determine actions of intestinal antisecretory compounds on potential difference in the Ussing chamber were done as described by Field.<sup>17</sup> Ileal segments from male New Zealand white rabbits were stripped of their serosa and then mounted in an Ussing chamber.

Determination of drug effect was made on at least two tissues which had been exposed to aminophylline to initiate net anion secretion into the luminal compartment of the Ussing chamber. Ten minutes after the addition of aminophylline, the test compounds were added to both sides of the ileal tissue at a final concentration of  $10^{-6}$  M. A compound was considered active if it returned the aminophylline-augmented PD to control values. If the compound had no effect on PD, the concentration was elevated to  $10^{-5}$  M on both sides of the tissue. Moderate activity was defined as a reduction of PD only at  $10^{-5}$  M. Inactive

- (12) (a) Allinger, N. L. *J. Am. Chem. Soc.* 1977, 99, 8127. (b) Allinger, N. L.; Yuh, Y. H. Quantum Chemistry Program Exchange; Program no. 395, 1977.
- (13) Hopfinger, A. J.; Pearlstein, R. A. *J. Comput. Chem.* 1984, 5, 486.
- (14) Halgren, T. A.; Kleier, D. A.; Hall, J. H., Jr.; Brown, L. D.; Lipscomb, W. N. *J. Am. Chem. Soc.* 1978, 100, 6595.
- (15) Jacoby, H. I.; Marshall, C. H. *Nature (London)* 1972, 235, 163.
- (16) Fisher, R. A. *Statistical Methods for Research Workers*, 14th ed.; Hafner: New York, 1970; Chapter 9.
- (17) (a) Field, M.; Fromm, D.; McColl, I. *Am. J. Physiol.* 1971, 220, 1388. (b) Chang, E. B.; Field, M.; Miller, R. *J. Am. J. Physiol.* 1982, 242, G237.

compounds did not change PD. Yohimbine, a specific competitive antagonist of  $\alpha_2$  receptors,<sup>17</sup> was always incubated after activity was seen. Reversal of PD changes was taken as evidence of  $\alpha_2$ -receptor activation.

### Results and Discussion

Table I shows the pharmacological results for those compounds most closely related to guanabenz. The activity was abolished by only minor alterations in structure: 17, the most potent compound in the entire study, with 2,6-dimethyl substitution, can be compared to the inactive 2-methyl analogue 18 or the very weakly active 2,4,6-trimethyl analogue 19. That steric effects per se did not entirely account for the lack of potency of 19 is shown by the relatively good potency of the 2,6-dimethyl-4-hydroxy analogue 20. The amino function, which had proved useful in other  $\alpha_2$ -agonist series in our hands,<sup>18,19</sup> did not confer activity in these compounds, as shown by 13, 14, and 16.

Activity in the Ussing chamber was only demonstrated by the most potent compound, 17. Prior (unpublished) experience in our laboratory has indicated that weakly active compounds in this series, such as 19 and 22, and in other chemical series as well are typically inactive in the Ussing chamber. The potency of 20 would, on the other hand, be expected to be sufficiently good to give a positive response in this apparatus. The cause of this discrepancy was not pursued.

Certain other alterations of 17 are shown in Table II. The precipitous loss of activity for 7 and 8 is most easily ascribed to the steric influence of the methyl group ( $R^1$ ) on the surface of the benzene residue opposite to the hydrazone moiety.

Compound 32 results from the incorporation of the guanidine moiety of the aminoguanidine hydrazone into a 2-aminoimidazole ring. This functionality has found effective use in clonidine (1), but in this series it resulted in a fivefold diminution of potency compared to that of 17.

Table III shows the activities of certain fused aromatic aldehyde aminoguanidine hydrazones. The aminoguanidine hydrazone of 1-naphthaldehyde (23) was mildly active in vivo and inactive in vitro, but the analogous 2-naphthaldehyde derivative 24 was inactive, as was the 4-quinoline aldehyde analogue 25.

Some fused-ring cyclic ketone derivatives were also studied, as shown in Table IV. The best of these compounds (26, 29) were only weakly active in vivo, and neither variation in ring size nor the use of alkyl ring substituents was helpful.

Three compounds, the highly potent 17 (2,6-dimethyl substituents), the inactive 18 (2-methyl substituent), and the weakly active 29 (6-methoxy-1-tetralone derivative) were chosen for computational chemical study, to investigate whether conformational energetics of these compounds might correlate with their in vivo activities.

A planar anti conformation is found to be lowest in energy for both 18 and 17. However, the minimum energy conformation is much nearer the rotational barrier, and the energy wells are much broader and shallower for the

dimethyl compound 17. As a result, this compound can adopt a nonplanar conformation much more readily than can compound 18. The saturated ring in 29 is slightly puckered, forcing the hydrazone moiety out of planarity with the aromatic residue. In addition, interaction of the nitrogen lone electron pair with nearby hydrogen atoms forces a further rotation from coplanarity by the terminal guanidine group.

Indeed, it is apparent that the startling difference in activity between 17 and 18 might well be explained by the radical difference in the population of out-of-aromatic-plane conformers with these two compounds. The out-of-aromatic-plane requirement of the basic center is well-known in the antihypertensive  $\alpha_2$  agonist pharmacological literature.<sup>20</sup> The weakly active 29 also has a meaningful out-of-aromatic-plane population, but its structural dissimilarity precludes a closer comparison with the two other compounds.

This survey of diverse aromatic aminoguanidine hydrazones finally yielded only two compounds of high potency when given by the subcutaneous route (17, 20). These compounds were inactive in the antihypertensive assay (spontaneously hypertensive rat), as were the other compounds described here. Of these, 20 showed the lowest incidence of side effects, including ataxia, a common side effect of centrally acting  $\alpha_2$  agonists. Follow-up testing in higher mammals demonstrated a lack of oral activity,<sup>21</sup> although 17 retained its potency by oral administration in the rat, so efforts were refocused upon other  $\alpha_2$ -adrenergic agonists.

### Experimental Section

**General Methods.** Reaction extracts were concentrated, after washing with water and drying over  $MgSO_4$ , on a rotary evaporator at reduced pressure, with the temperature maintained below 40 °C. Column chromatography was performed on a medium-pressure glass column using silica gel 60 (Merck) or on a Waters Prep 500 instrument using Porasil. Thin-layer chromatography was performed with 90:10:0.1 methylene chloride/methanol/concentrated ammonium hydroxide. Proton NMR spectra were measured in  $DMSO-d_6$  unless indicated otherwise, with TMS (0 ppm) as an internal standard on a Varian A-60 or FT-80 spectrometer; IR spectra were measured in KBr disks unless indicated otherwise, on a Perkin-Elmer 283b or 681. Microanalyses were performed for the stated elements and were within  $\pm 0.4\%$  of the theoretical values for the stated empirical formula. Melting points are corrected and measured on a Thomas-Hoover capillary melting point apparatus.

2-[(2,6-Dimethylphenyl)methylene]hydrazinecarboximidamide Nitrate (17). 2,6-Dimethylbenzaldehyde (5.2 g, 40 mmol) and aminoguanidine nitrate (5.2 g, 40 mmol) were suspended in 60 mL of MeOH. Concentrated  $H_2SO_4$  (2.0 mL) was added dropwise, and complete solution was followed by crystallization. The progress of the reaction was followed by TLC, and when the reaction was complete (ca. 3 h), 50% NaOH was added to a pH of 10. The solid was filtered, washed with  $H_2O$ , and then dried to yield 5.8 g (57%) of 17, mp 189–205 °C. Anal. ( $C_{10}H_{14}N_4 \cdot HNO_3$ ) C, H, N.

2-[(4-Hydroxy-2,6-dimethylphenyl)methylene]hydrazinecarboximidamide Hydrochloride (20). 2,6-Dimethyl-4-hydroxybenzaldehyde (10.0 g, 66 mmol) and aminoguanidine nitrate (9.1 g, 66 mmol) were reacted in 100 mL of MeOH with 1.5 mL of concentrated  $H_2SO_4$  as described for 17. The resulting nitrate salt (17.5 g) was dissolved in 50% NaOH and filtered to remove any insoluble material. This solution was poured into 100 mL of concentrated HCl/400 mL of  $H_2O$ . Crystals slowly formed. The solid was filtered, washed with  $H_2O$ , and then

- (18) Moormann, A. E.; Pitzele, B. S.; Jones, P. H.; Gullikson, G. W.; Bianchi, R. G.; Monroy, M.; Rubin, B.; Casler, J.; Grebner, M.; Yu, S. S. *Abstracts of Papers*, 190th National Meeting of the American Chemical Society, Chicago, IL; American Chemical Society: Washington, DC, 1985; MEDI 72.
- (19) Pitzele, B. S.; Yu, S. S.; Hamilton, R. W.; Moormann, A. E.; Gullikson, G. W.; Bianchi, R. G.; Dajani, E. Z.; Palicharla, P. *Abstracts of Papers*, 190th National Meeting of the American Chemical Society, Chicago, IL; American Chemical Society: Washington, DC, 1985; MEDI 73.

- (20) Timmermans, P. B. M. W. M.; Hoefke, W.; Stahle, H.; Van Zweiten, P. A. *Prog. Pharmacol.* 1980, 3, 85.
- (21) Gullikson, G. W., personal communication. An account of this work will appear elsewhere.
- (22) Braude, E. A.; Erskine, R. L. *J. Chem. Soc.* 1956, 4673.

suction-dried to yield 10.4 g (65%) of **20**, mp 263–267 °C. Anal. (C<sub>10</sub>H<sub>14</sub>N<sub>4</sub>O·HCl) C, H, Cl, N.

**2-[(2,4,6-Trimethylphenyl)methylene]hydrazinecarboximidamide (19)**. Mesitaldehyde (3.0 g, 20 mmol) and aminoguanidine nitrate (2.7 g, 20 mmol) were reacted in 30 mL of MeOH and 1.0 mL of concentrated H<sub>2</sub>SO<sub>4</sub> as described for **17**. The pH of the filtrate was adjusted to 13 with 50% NaOH, and the solid was filtered, washed with H<sub>2</sub>O, and suction-dried to yield 600 mg (17%) of **19**, mp 229–232 °C. Anal. (C<sub>11</sub>H<sub>16</sub>N<sub>4</sub>) C, H, N.

**2-(1-Naphthalenylmethylene)hydrazinecarboximidamide Hydrochloride (23)**. 1-Naphthaldehyde (6.0 g, 40 mmol) and aminoguanidine nitrate (5.2 g, 40 mmol) were reacted in 30 mL of MeOH with 2.0 mL of concentrated H<sub>2</sub>SO<sub>4</sub> and converted to the HCl salt as described for **17** to yield 7.29 g (72%) of **23**, mp 179–184 °C. Anal. (C<sub>12</sub>H<sub>12</sub>N<sub>4</sub>·HCl) C, H, Cl, N.

**2-(2-Naphthalenylmethylene)hydrazinecarboximidamide Sulfate (24)**. 2-Naphthaldehyde (5.0 g, 32 mmol) and aminoguanidine hemisulfate (3.9 g, 32 mmol) were suspended in 50 mL of MeOH, and 2.0 mL of concentrated H<sub>2</sub>SO<sub>4</sub> was added. The reaction was monitored by TLC. When the starting material was consumed (16 h), the solid was filtered, washed well with MeOH, and then suction-dried to yield 7.5 g (75%) of **24**, mp 223–227 °C. Anal. (C<sub>12</sub>H<sub>12</sub>N<sub>4</sub>·H<sub>2</sub>SO<sub>4</sub>) C, H, N, S.

**2-(4-Quinolinylmethylene)hydrazinecarboximidamide Sesquisulfate (25)**. 4-Quinolincarboxaldehyde (2.5 g, 15.9 mmol) and aminoguanidine hemisulfate (1.9 g, 15.9 mmol) in 30 mL of MeOH with 1.0 mL of concentrated H<sub>2</sub>SO<sub>4</sub> were reacted as described for **17** to yield 5.7 g (99%) of **25**, mp 263–266 °C. Anal. (C<sub>11</sub>H<sub>11</sub>N<sub>5</sub>·1½H<sub>2</sub>SO<sub>4</sub>) C, H, N, S.

**1-(2-Imidazolidinylidene)-2-[(2,6-dimethylphenyl)methylene]hydrazine (32)**. 2,6-Dimethylbenzaldehyde (3.7 g, 27 mmol) and 2-hydrazino-2-imidazolinehydrobromide (5.0 g, 0.027 mol) in 60 mL of MeOH with 1.5 mL of concentrated H<sub>2</sub>SO<sub>4</sub> were reacted as described for **17**. The pH was adjusted to 11 with 50% NaOH, and the mixture was poured into H<sub>2</sub>O. The resulting solid was washed with H<sub>2</sub>O followed by Et<sub>2</sub>O and then suction-dried to yield 2.3 g (39%) of **32**, mp 180.5–182.5 °C. Anal. (C<sub>12</sub>H<sub>16</sub>N<sub>4</sub>) C, H, N.

**2-[(4-Hydroxy-3,5-dimethylphenyl)methylene]hydrazinecarboximidamide Hydrochloride (21)**. NaOH (22.0 g, 550 mmol) was dissolved in EtOH (100 mL) and H<sub>2</sub>O (50 mL). 2,6-Dimethylphenol (6.1 g, 50 mmol) was added, and the reaction mixture was heated to reflux. The heating source was removed, and 17.9 g (0.15 mol) of chloroform was added at a rate to maintain reflux (very exothermic!) The reaction mixture was cooled, the pH was adjusted to 6 with concentrated HCl, and the solid was filtered. H<sub>2</sub>O (150 mL) was added to the filtrate, which was extracted thrice with Et<sub>2</sub>O. The organic phase was washed with H<sub>2</sub>O, dried, and concentrated to an oil, which was chromatographed over silica gel and eluted with EtOAc/petroleum ether. This yielded 1.2 g of a solid. Anal. (C<sub>9</sub>H<sub>10</sub>O<sub>2</sub>) C, H.

This aldehyde (1.2 g, 8 mmol) and aminoguanidine nitrate (1.1 g, 8 mmol) were reacted in 20 mL of MeOH with 0.5 mL of concentrated H<sub>2</sub>SO<sub>4</sub> and converted to the HCl salts as described above (**17**), to yield 600 mg (30%) of **21**, mp 267–271 °C. Anal. (C<sub>10</sub>H<sub>14</sub>N<sub>4</sub>O·HCl) C, H, Cl, N.

**2-[(4-Methoxy-2,6-dimethylphenyl)methylene]hydrazinecarboximidamide (22)**. 2,6-Dimethyl-4-hydroxybenzaldehyde (6.0 g, 40 mmol) and dimethyl sulfate (10.4 g, 80 mmol) were dissolved in 60 mL of EtOH. NaOH (50% in H<sub>2</sub>O, w/w) (12.8 g, 160 mmol) was added dropwise, and the reaction mixture was stirred for 1 h. The reaction mixture was poured into 0.5 L of H<sub>2</sub>O, and the solid was filtered, washed with H<sub>2</sub>O, and suction-dried to yield 5.5 g of the crude methoxy aldehyde. The crude methoxy aldehyde (5.5 g, 33 mmol) and aminoguanidine nitrate (4.6 g, 33 mmol) were reacted in MeOH (50 mL) with 1.0 mL of concentrated H<sub>2</sub>SO<sub>4</sub> as described for **17**. The free base was isolated by adjusting the pH to 13 with 50% NaOH and pouring into H<sub>2</sub>O. The solid was filtered, washed well with H<sub>2</sub>O, and suction-dried to yield 7.1 g (97%) of **22**, mp 225–230 °C. Anal. (C<sub>11</sub>H<sub>16</sub>N<sub>4</sub>O) C, H, N.

**2-[(2-Methylphenyl)methylene]hydrazinecarboximidamide (18)**. *o*-Tolualdehyde (4.8 g, 40 mmol) and aminoguanidine nitrate (5.2 g, 40 mmol) were reacted in 60 mL of MeOH with 1.0 mL of concentrated H<sub>2</sub>SO<sub>4</sub>, and the free base was isolated as described for **22**. This solid was chromatographed over silica gel

and eluted with MeOH/CH<sub>2</sub>Cl<sub>2</sub>/NH<sub>4</sub>OH. This yielded 3.0 g (42%) of **18**, mp 145–148 °C. Anal. (C<sub>9</sub>H<sub>12</sub>N<sub>4</sub>) C, H, N.

**2-[1(Z)-(2,6-Dimethylphenyl)ethylidene]hydrazinecarboximidamide (7) and 2-[1(E)-(2,6-Dimethylphenyl)ethylidene]hydrazinecarboximidamide (8)**. 2,6-Dimethylacetophenone<sup>22</sup> (3.7 g, 25 mmol) and aminoguanidine hemisulfate (3.1 g, 25 mmol) were reacted in 35 mL of MeOH with 1 mL of concentrated H<sub>2</sub>SO<sub>4</sub> for 3 h. The mixture was isolated as the free base as described for **22**, chromatographed over silica gel, and eluted with MeOH/CH<sub>2</sub>Cl<sub>2</sub>/NH<sub>4</sub>OH. This separated the syn (**7**) and anti (**8**) isomers. Each was suspended in 4:1 Et<sub>2</sub>O/petroleum ether, filtered, and dried in a vacuum oven, to yield 525 mg of **8** and 154 mg of **7**, both as solids. Compound **7** was isolated and characterized as a hexane solvate, mp 140–145 °C. Anal. (C<sub>11</sub>H<sub>16</sub>N<sub>4</sub>·½C<sub>6</sub>H<sub>14</sub>) C, H, N. Compound **8** was isolated as the anhydrous material, mp 177–189 °C. Anal. (C<sub>11</sub>H<sub>16</sub>N<sub>4</sub>) C, H, N.

**2-[(3,5-Diamino-2,6-dimethylphenyl)methylene]hydrazinecarboximidamide (16)**. 2,6-Dimethylbenzaldehyde (11.1 g, 83 mmol) was added dropwise to a mixture of 50 mL of concentrated H<sub>2</sub>SO<sub>4</sub> and 7.0 mL of fuming HNO<sub>3</sub> (166 mmol) at –10 °C, and the temperature was kept below 0 °C for 15 min. The mixture was poured onto ice and diluted to 500 mL with H<sub>2</sub>O. The solid was filtered, washed well with H<sub>2</sub>O, and air-dried to yield 12.6 g of a solid, 2,6-dimethyl-3,5-dinitrobenzaldehyde (**15**). This aldehyde (4.4 g, 20 mmol) was reacted with aminoguanidine nitrate (2.7 g, 20 mmol) with 1.0 mL of concentrated H<sub>2</sub>SO<sub>4</sub> in 35 mL of MeOH as described for **17** to yield 3.8 g of the corresponding aminoguanidine hydrazone. This hydrazone was hydrogenated in 40 mL of 1:1 MeOH/THF over 5% Pd/C. After removal of the catalyst, the solvent was evaporated, the residue was dissolved in MeOH, and 0.5 mL of concentrated HCl was added. Ether was added, and the resulting solid was filtered, washed well with Et<sub>2</sub>O, and then suction-dried to yield 4.0 g (87%) of **16**, mp 230–235 °C dec. Anal. (C<sub>10</sub>H<sub>16</sub>N<sub>6</sub>·3HCl·½CH<sub>3</sub>OH·¼H<sub>2</sub>O) C, H, Cl, N.

**2-Methyl-5-nitrobenzaldehyde (12)**. *o*-tolualdehyde (100 g, 830 mmol) was added dropwise to a mixture of 70 mL of fuming HNO<sub>3</sub> (1.66 mol) in 520 mL of H<sub>2</sub>SO<sub>4</sub> as above. After the reaction mixture was poured onto ice, the product was extracted into Et<sub>2</sub>O. The organic phase was washed well with saturated NaHCO<sub>3</sub> and then with water, then dried, and evaporated to an oil, which was a mixture of 2-methyl-3-nitrobenzaldehyde and **12**. This mixture (16.5 g, 100 mmol) was combined with 9.9 g (0.1 mol) of cyclohexylamine. A few drops of 50% NaOH were added, and a precipitate (**10**) formed. The solid was filtered, washed with MeOH, and suction-dried, giving 11.2 g of the pure **10**. The filtrate was used in the preparation of **11**. The solid **10** was dissolved in 1 N HCl and extracted with Et<sub>2</sub>O. The Et<sub>2</sub>O layer was washed with H<sub>2</sub>O and dried over MgSO<sub>4</sub>, and the solvent was stripped. The solid residue was suspended in petroleum ether, filtered, and suction-dried to yield 6.5 g of 2-methyl-5-nitrobenzaldehyde (**12**): NMR (CDCl<sub>3</sub>) δ 2.80 (s, 3 H), 7.45 (d, 1 H), 8.28 (d of d, 1 H), 8.62 (d, 1 H), 10.3 (s, 1 H). Anal. (C<sub>8</sub>H<sub>7</sub>NO<sub>3</sub>) C, H, N.

**2-[(5-Amino-2-methylphenyl)methylene]hydrazinecarboximidamide Dihydrochloride (14)**. Compound **12** (6.5 g, 39 mmol) was reacted with aminoguanidine nitrate (5.4 g) with 1.0 mL of concentrated H<sub>2</sub>SO<sub>4</sub> in 100 mL of MeOH and isolated as described for **17** to yield 4.4 g of the corresponding aminoguanidine hydrazone. This compound (4.4 g, 20 mmol) was hydrogenated and isolated as the HCl salt as described for **16** to yield 5.0 g of **14**, mp 230–235 °C dec. Anal. (C<sub>9</sub>H<sub>13</sub>N<sub>5</sub>·2HCl·½CH<sub>3</sub>OH·H<sub>2</sub>O) C, H, Cl, N.

**2-Methyl-3-nitrobenzaldehyde (11)**. The filtrate from the condensation of cyclohexylamine and *o*-tolualdehyde (see preparation of **12**), a mixture of **9** and **10**, was chromatographed over silica gel eluting with EtOAc/hexane, giving (separately) pure **9** and **10**. Compound **9** was hydrolyzed to **11** and isolated as described in the preparation of **12**, to yield 1.0 g of a solid: NMR (CDCl<sub>3</sub>) δ 2.78 (s, 3 H), 7.55 (d, 1 H), 8.0 (m, 2 H), 10.38 (s, 1 H).

**2-[(3-Amino-2-methylphenyl)methylene]hydrazinecarboximidamide Dihydrochloride (13)**. Compound **11** (1.0 g, 6 mmol) was converted to the hydrazone with 830 mg (6 mmol) of aminoguanidine nitrate with 1.0 mL of concentrated H<sub>2</sub>SO<sub>4</sub> and 20 mL of MeOH as above to yield 1.0 g of a solid. This solid was hydrogenated as described for **16** and isolated as the dihydrochloride salt to yield 1.0 g of **13**, mp 243–254 °C. Anal.

[C<sub>9</sub>H<sub>13</sub>N<sub>5</sub>·2HCl·<sup>1</sup>/<sub>2</sub>H<sub>2</sub>O·<sup>1</sup>/<sub>8</sub>(C<sub>2</sub>H<sub>5</sub>)<sub>2</sub>O] C, H, Cl, N.

**2-(1,2,3,4-Tetrahydro-1-naphthalenyldene)hydrazinecarboximidamide (26).** A 250-mL Erlenmeyer flask was charged with aminoguanidine nitrate (10 g, 72.9 mmol), methanol (125 mL), and  $\alpha$ -tetralone (9.70 mL, 10.66 g, 72.9 mmol). The mixture was stirred, and concentrated sulfuric acid (4.1 mL, 72.9 mmol) was added. The mixture warmed, and the precipitate soon appeared. After an hour of stirring, a solution of KOH (9.63 g, 146 mmol) in methanol (50 mL) was added. After 15 min of stirring, the mixture was filtered. The solid was washed with water thrice to remove K<sub>2</sub>SO<sub>4</sub> and then washed with acetone, giving the impure nitrate salt of the desired product. The filtrate from the KOH addition was diluted to 500 mL with H<sub>2</sub>O and adjusted to pH 13 with 50% aqueous NaOH. The resulting mixture was filtered while warm, and the filtrate was rapidly extracted twice with ethyl acetate. The organic layers were combined, dried (saturated brine), filtered, and stripped to give analytically pure **26** as the free base, mp 176.5–183.5 °C. Anal. (C<sub>11</sub>H<sub>14</sub>N<sub>4</sub>) C, H, N.

**2-(1-Indanylidene)hydrazinecarboximidamide Nitrate (27).** This synthesis was run as described for **26**, up to the isolation of the crude solid product nitrate salt. This solid was washed thoroughly with methanol, then thrice with water, and then sequentially with acetone/methanol, 2-propanol, and water again. The resulting solid was dried in vacuo (aspirator) at 48 °C in a stream of N<sub>2</sub> overnight, giving the desired product, mp 260–266 °C. Anal. (C<sub>10</sub>H<sub>12</sub>N<sub>4</sub>·HNO<sub>3</sub>) C, H, N.

**2-(1,2,3,4-Tetrahydro-7-methoxy-1-naphthalenyldene)hydrazinecarboximidamide Sulfate (28).** A 500-mL Erlenmeyer flask was charged with 7-methoxytetralone (7.16 g, 40.6 mmol), methanol (200 mL), and aminoguanidine hemisulfate (5.0 g, 20.3 mmol, 40.6 mequiv). The opaque white suspension was stirred, and concentrated H<sub>2</sub>SO<sub>4</sub> (2.26 mL, 40.6 mmol) was added dropwise. The resulting water-white solution was stirred overnight and then diluted to 1 L with Et<sub>2</sub>O. The resulting crystals were washed thrice with Et<sub>2</sub>O and dried in a vacuum oven at 30 °C (aspirator pressure) overnight, giving the desired product (90%), mp 175–178 °C. Anal. (C<sub>12</sub>H<sub>16</sub>N<sub>4</sub>O·H<sub>2</sub>SO<sub>4</sub>) C, H, N, S.

**2-(1,2,3,4-Tetrahydro-6-methoxy-1-naphthalenyldene)hydrazinecarboximidamide Sulfate (29).** This synthesis was run as described for **28**, with the following changes: 6-Methoxytetralone was the starting ketone. The reaction was complete after 2 h of stirring of all the reagents, and solid was always present. The product crystals were washed with methanol and then Et<sub>2</sub>O. The yield was 89%, mp 213–214 °C. Anal. (C<sub>12</sub>H<sub>16</sub>N<sub>4</sub>O·H<sub>2</sub>SO<sub>4</sub>) C, H, N, S.

**2-(1,2,3,4-Tetrahydro-5-methoxy-1-naphthalenyldene)hydrazinecarboximidamide Sulfate (30).** This synthesis was run as described for **29**, except that the starting ketone was 5-methoxytetralone. The yield was 89%, mp 231–232 °C. Anal. (C<sub>12</sub>H<sub>16</sub>N<sub>4</sub>O·H<sub>2</sub>SO<sub>4</sub>) C, H, N, S.

**2-(1,2,3,4-Tetrahydro-2-methyl-1-naphthalenyldene)hydrazinecarboximidamide (31).** A 250-mL flask was charged with a magnetic stirrer, 2-methyltetralone (10 g, 62.4 mmol), MeOH (100 mL), and aminoguanidine hemisulfate (7.32 g, 29.7 mmol, 59.4 mequiv). The mixture was stirred, and concentrated H<sub>2</sub>SO<sub>4</sub> (3.3 mL) was added. The opaque suspension was refluxed for 6 h and then stripped to a syrup. The syrup was triturated four times with ether, and the resulting solid was recrystallized from 2-propanol. This partially purified hemisulfate (13.9 g) was suspended in CH<sub>2</sub>Cl<sub>2</sub> (150 mL). A NaOH solution (12%, w/v, 50 mL) was added with stirring. After 1 h of stirring, the mixture was filtered, and the solid was washed with H<sub>2</sub>O and then with CH<sub>2</sub>Cl<sub>2</sub>. This solid was dried and recrystallized from MeOH/H<sub>2</sub>O to give the desired product as the free base (5.7 g, 42%), mp 180–180.5 °C. Anal. (C<sub>12</sub>H<sub>16</sub>N<sub>4</sub>) C, H, N.

**Pharmacology. Cholera-Induced Intestinal Fluid Secretion.** In order to determine the effects of the test compounds on intestinal fluid movements, we used the rat cholera secretion model.<sup>15</sup> Female Charles River rats weighing 85–100 g with free access to water were fasted for 24 h prior to each experiment. Under ether anesthesia, a midline incision was made and a 20 cm ligated small intestinal segment was constructed starting 3.0 cm distal to the ligament of Treitz. Each segment was injected with equivalent secretory doses of either 1.0 mL of a 40 mg/mL saline solution of crude cholera toxin [Cholera Advisory Board, National Institutes of Allergy and Infectious Disease (Lot #001-

Wyeth)] or 1.0 mL of saline containing 160  $\mu$ g of cholera toxin (List Biologicals, Campbell, CA).

Injections into the jejunum were made with a 27-gauge <sup>1</sup>/<sub>2</sub>-in. needle. Animals were sacrificed 4 h later and the fluid content and exact length of the intestinal segments measured. Fluid secretion was expressed in milliliters/centimeter of intestine. Compounds were administered subcutaneously to groups of four rats at doses of 10 and 20 mg/kg 30 min prior to cholera toxin injection into the intestinal segment. The volumes obtained after compound treatment were compared to those of controls which did not receive drug.

The ID<sub>50</sub>'s of these compounds were estimated from data on at least two doses and from at least two different experiments, by the method of maximum likelihood.<sup>16</sup>

**Ussing Chamber Transport Experiments.** Male New Zealand white rabbits weighing between 2 and 3 kg were killed by cervical dislocation.<sup>17</sup> A 40–50-cm segment of distal ileum was removed, washed thoroughly with cold saline, and placed in an ice-cold oxygenated modified Krebs buffer (composition in millimoles/liter: NaCl, 118; KCl, 4.7; MgSO<sub>4</sub>·7H<sub>2</sub>O, 1.2; CaCl<sub>2</sub>, 2.5; KH<sub>2</sub>PO<sub>4</sub>, 1.2; NaHCO<sub>3</sub>, 25; and glucose, 1.1). The ileal segments were then stripped of serosa and muscularis by drawing the tissue over a 10-mL pipet and using a sharp scalpel for dissection. A 2.5-cm segment of mucosa was then mounted between two Plexiglas chambers, providing an exposed mucosal area of 1.23 cm<sup>2</sup>.

Modified Krebs buffer (10 mL) was introduced into the chambers on both mucosal and serosal sides of the ileal mucosa. The buffer was oxygenated with 95% O<sub>2</sub>/5% CO<sub>2</sub> and kept at 37 °C and pH 7.4.

Potential difference (PD) measurements on isolated ileal mucosa were made at 5-min intervals by using a 742C dual voltage clamp (Bioengineering Department, University of Iowa, Iowa City, IA). Tissue PD was monitored with matched reference electrodes (Fisher Scientific, Cat. No. 13-639-79) connected to the chambers by salt-agar bridges containing Krebs solution and 2% agar.

Determination of drug effect was made on at least two tissues which had been exposed for 10 min to 5 × 10<sup>-3</sup> M aminophylline to initiate net anion secretion into the luminal compartment of the Ussing chamber. Ten minutes after the addition of aminophylline, the test compounds were added to both sides of the ileum at a final concentration of 10<sup>-6</sup> M. A compound was considered active if it returned the aminophylline-augmented PD to control values. If the compound had no effect on PD, the concentration of the compound was raised to 10<sup>-5</sup> M on both sides of the tissue. Moderate activity was defined as a reduction of PD only at 10<sup>-5</sup> M. Inactive compounds did not change PD. Yohimbine, a specific competitive antagonist of  $\alpha_2$  receptors, was always incubated at 10<sup>-6</sup> M after activity was seen to determine whether  $\alpha_2$ -receptor activation was responsible.

**Antihypertensive Assay.** Unanesthetized, 11–16-week-old male spontaneously hypertensive rats were fitted with a caudal plethysmograph, and a blood pressure reading was made immediately before administration of compound (ig, 50 mg/kg).

Blood pressure readings were repeated 4 h after administration of the compound. A dose of test compound was rated active if the posttreatment blood pressures of the treated rats were significantly lower ( $P \leq 0.05$ ) than the initial pressure reading. Statistical comparisons were made by using the nonpaired Student's *t* test.

**Computational Chemistry.** Molecular modeling studies were carried out by using Chemlab II (Molecular Design Ltd., San Leandro, CA). Structures **18** and **17** were generated from standard bond lengths and angles and then fully optimized by using a modified version of Allinger's MM2 program,<sup>12</sup> with additional parameters generated by the method of Hopfinger and Pearlstein.<sup>13</sup> For compound **29**, the X-ray crystallographic conformation was used; only hydrogen positions were optimized with molecular mechanics. Conformational energies were calculated by using the approximate ab initio method PRDDO.<sup>14</sup> The optimized structures described above were used as starting points, and fixed valence geometry torsional rotations were carried out in 30° increments.

**Acknowledgment.** Microanalyses were performed by E. Zielinski and his staff. Spectroscopic support was from

A. Damascus and his staff. Consultations on NMR analyses were with L. Swenton and P. Finnegan. All of the above persons are in the Physical Methodology Department of G.D. Searle R&D. Single-crystal X-ray analysis was performed by Dr. C. K. Schauer under the direction of Prof. Oren Anderson at Colorado State University, Ft. Collins, CO, using a Nicolet R3m-E diffractometer supplied by NSF CHE-8103011. Manuscript preparation was by G. Koek and P. Polin.

**Registry No.** 7, 111159-74-1; 8, 111159-75-2; 9, 111159-76-3; 10, 111159-77-4; 11, 23876-12-2; 11(aminoguanidine hydrazone), 111159-96-7; 12, 16634-91-6; 12(aminoguanidine hydrazone), 111159-95-6; 13, 111159-78-5; 13·2HCl, 111160-04-4; 14, 111159-79-6; 14·2HCl, 111160-03-3; 15, 111159-80-9; 15(aminoguanidine hydrazone), 111159-94-5; 16, 111159-81-0; 16·3HCl, 111160-02-2; 17, 111159-82-1; 17·HNO<sub>3</sub>, 111160-12-4; 18, 111159-83-2; 19, 111159-84-3; 20, 111159-85-4; 20·HCl, 111159-97-8; 21, 111159-86-5; 21·HCl, 111160-01-1; 22, 111159-87-6; 23, 6928-06-9; 23·HCl, 111159-98-9; 24, 6928-07-0; 24·H<sub>2</sub>SO<sub>4</sub>, 111159-99-0; 25, 74618-23-8; 25·1<sup>1</sup>/<sub>2</sub>H<sub>2</sub>SO<sub>4</sub>, 111160-00-0; 26, 72189-66-3; 27, 111159-88-7; 27·

HNO<sub>3</sub>, 111822-63-0; 28, 111159-89-8; 28·H<sub>2</sub>SO<sub>4</sub>, 111160-06-6; 29, 111159-90-1; 29·H<sub>2</sub>SO<sub>4</sub>, 111160-08-8; 29·1<sup>1</sup>/<sub>2</sub>H<sub>2</sub>SO<sub>4</sub>·1<sup>1</sup>/<sub>2</sub>H<sub>2</sub>O, 111822-62-9; 30, 111159-91-2; 30·H<sub>2</sub>SO<sub>4</sub>, 111160-10-2; 31, 111159-92-3; 32, 111159-93-4; 2,6-(Me)<sub>2</sub>C<sub>6</sub>H<sub>3</sub>CHO, 1123-56-4; 2,6-(Me)<sub>2</sub>-4-OH-1-(CHO)C<sub>6</sub>H<sub>2</sub>, 70547-87-4; NH<sub>2</sub>C(=NH)NHNH<sub>2</sub>·H<sub>2</sub>·HNO<sub>3</sub>, 10308-82-4; NH<sub>2</sub>C(=NH)NHNH<sub>2</sub>·1<sup>1</sup>/<sub>2</sub>H<sub>2</sub>SO<sub>4</sub>, 996-19-0; 2,6-(Me)<sub>2</sub>C<sub>6</sub>H<sub>3</sub>OH, 576-26-1; 3,5-(Me)<sub>2</sub>-4-OH-1-(CHO)C<sub>6</sub>H<sub>2</sub>, 2233-18-3; 2,6-(Me)<sub>2</sub>-4-OMe-1-(CHO)C<sub>6</sub>H<sub>2</sub>, 19447-00-8; *o*-MeC<sub>6</sub>H<sub>4</sub>CHO, 529-20-4; 2,6-(Me)<sub>2</sub>C<sub>6</sub>H<sub>3</sub>Ac, 2142-76-9; mesitaldehyde, 487-68-3; 1-naphthaldehyde, 66-77-3; 2-naphthaldehyde, 66-99-9; 4-quinolinecarboxaldehyde, 4363-93-3; 2-hydrazine-2-imidazoline hydrobromide, 55959-84-7;  $\alpha$ -tetralone, 529-34-0; 1-indanone, 83-33-0; 7-methoxytetralone, 6836-19-7; 6-methoxytetralone, 1078-19-9; 5-methoxytetralone, 33892-75-0; 2-methyltetralone, 1590-08-5.

**Supplementary Material Available:** Spectroscopic data (NMR, IR) on target compounds, single-crystal X-ray data on 29, including unit cell dimensions, space group, and atomic coordinates with their estimated precision, and structures and figures (energy vs rotation graphs) for computational chemistry on 17, 18, and 29 (12 pages). Ordering information is given on any current masthead page.

## Effect of Acyclic Pyrimidines Related to 9-[(1,3-Dihydroxy-2-propoxy)methyl]guanine on Herpesviruses

Lilia M. Beauchamp,\* Barbara L. Serling, John E. Kelsey, Karen K. Biron, Peter Collins,† John Selway,† Jung-Chung Lin,† and Howard J. Schaeffer

The Wellcome Research Laboratories, Research Triangle Park, North Carolina 27709. Received March 26, 1987

A series of pyrimidines related to the potent antiherpetic agent 9-[(1,3-dihydroxy-2-propoxy)methyl]guanine (1, BW B759U), all containing the same acyclic chain, have been synthesized. Some of the compounds were derivatives of the naturally occurring bases, cytosine, uracil, and thymine; others included compounds in which the 5-position of the cytosine and uracil moieties were substituted by bromo, iodo, fluoro, methyl, and amino groups. Other variations of the cytosine derivatives were the 5-aza, 2-mercapto, 4-methylamino, 4-dimethylamino, and isocytosine congeners. A 4-aminopyrimidine adduct was also made. Antiviral testing showed that 1-[(1,3-dihydroxy-2-propoxy)methyl]cytosine (18, BW A1117U) was equivalent to the guanine analogue in potency against human cytomegalovirus and Epstein Barr virus. Other compounds in the series were largely inactive in antiviral screening against the herpesviruses.

The acyclic nucleoside 9-[(1,3-dihydroxy-2-propoxy)methyl]guanine (1, BW B759U, ganciclovir) is undergoing clinical trials for the treatment of cytomegalovirus (CMV) infections in immunocompromised and AIDS patients. This compound, which has been independently reported by us<sup>1</sup> and others,<sup>2</sup> exhibits a broad spectrum of activity against the family of herpesviruses, similarly to the parent, 9-[(2-hydroxyethoxy)methyl]guanine, acyclovir (ACV, Zovirax).<sup>3</sup> However, 1 is a much more potent anti-CMV agent (IC<sub>50</sub> = 2–10  $\mu$ M vs 90–200  $\mu$ M for ACV). Both compounds are members of a heterocyclic series possessing open acyclic chain functions that mimic the closed sugar groups of naturally occurring nucleosides.

As part of an ongoing program of evaluating acyclic nucleosides in these laboratories, we have synthesized pyrimidines alkylated with acyclic chains similar to that of acyclovir, but none have shown any significant antiviral activity.<sup>4</sup> We now report the results of the syntheses and the in vitro virological testing of pyrimidines bearing the (1,3-dihydroxy-2-propoxy)methyl substituent.

**Chemistry.** Our principal targets in the series were derivatives of cytosine, uracil, and thymine. Scheme I illustrates the sequence used to synthesize the requisite acyclic chain, all commencing with 1,3-dichloro-2-propanol

Scheme I

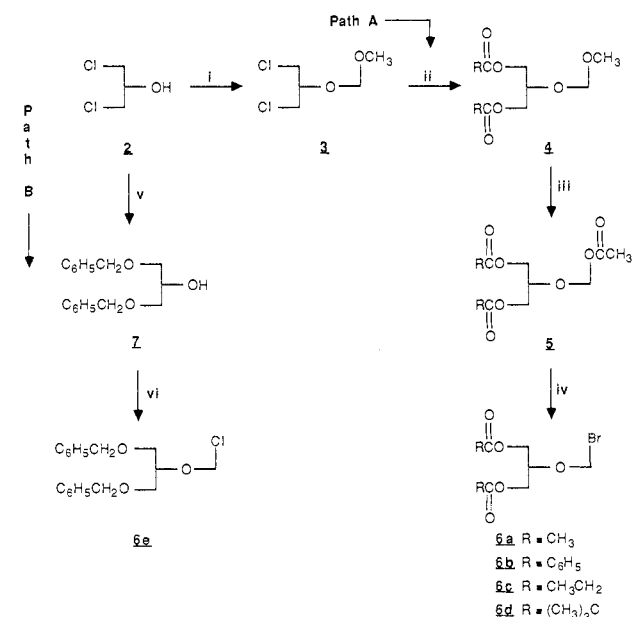

(2). The choice of protecting groups for the hydroxy termini was governed by well-known difficulties in the

\*The Wellcome Research Laboratories, Beckenham, Kent BR3 3BS, England.

†Lineberger Cancer Research Center, School of Medicine, University of North Carolina at Chapel Hill, Chapel Hill, NC 27514.